

Innovative transmission topologies using the example of a P2-hybridtransmission for front-transverse applications

Dipl.-Ing. **Tom Smejkal**, Dr.-Ing. **Christian Wirth**, ZG GmbH, Munich

Zusammenfassung

Kundenanforderungen bezüglich höheren Komforts führen zu einer zunehmenden Verbreitung von Automatikgetrieben im Bereich kompakter, frontgetriebener Fahrzeuge. Der hierfür notwendige Quereinbau des Getriebes stellt hohe Bauraumanforderungen hinsichtlich axialer Länge. Bisherige Serienlösungen für Automatikgetriebe nutzen zur Bauraumeinsparung entweder den Ansatz einer Schachtelung herkömmlicher Elemente oder ersetzen Lamellen- durch kompaktere Klauenschaltelemente. Weiterhin lässt sich eine oftmals gewünschte Hybridvariante als P2-Struktur, auch bei Entfall des Drehmomentwandlers, nur für kleine E-Maschinen darstellen.

Mithilfe des von der ZG GmbH entwickelten Getriebesyntheseprogramms "PlanGear" können neuartige Getriebetopologien synthetisiert werden, die aus Planetengetrieben, Stirnradstufen, Klauenschaltelementen und mehr als zwei Lastschaltelementen bestehen. Trotzdem ermöglichen diese Strukturen eine uneingeschränkte Lastschaltbarkeit. Durch eine verringerte Anzahl an Lastschaltelementen in Verbindung mit kompakten Klauenkupplungen können auch in bauraumrestriktiven Anwendungen Planetenautomatgetriebe (AT) als P2-Hybridstruktur umgesetzt werden. Damit eignen sich derartig generierte Topologien hervorragend für Getriebe mit hoher Leistungsdichte in eingeschränkten Bauräumen.

Im Vortrag wird ein neuartiges Hybridgetriebe vorgestellt, das durch den Einsatz von Klauenschaltelementen nicht nur Verluste sondern auch Bauraum gegenüber herkömmlichen AT einspart und dabei die volle Lastschaltbarkeit gewährleistet (Hoch- und Rückschaltungen). Das vorgeschlagene Getriebe besteht aus lediglich drei Planetenradstufen. Mit nur drei Lastschaltelementen und drei Klauenschaltelementen lassen sich sechs geometrisch gestufte Vorwärtsgänge darstellen. Unter Verwendung einer weiteren Umschalteneinrichtung ist ein mechanischer Rückwärtsgang sehr kompakt integrierbar.

Die Struktur des Getriebes sowie die Leistungsflüsse und Schaltbarkeit der Gänge werden erläutert. Weiterhin werden anhand der vorläufigen Konstruktion einer P2-Hybridstruktur die resultierenden Getriebeabmessungen dargestellt.

Abstract

Customer requirements regarding higher comfort lead to an increasing prevalence of automated transmissions in the area of compact, front-driven vehicles. The necessary transverse installation of the transmission imposes high installation space requirements on the axial length. Existing serial solutions for automated transmissions aim to reduce installation space by nesting conventional elements or replacing friction discs by compact dog clutches. Furthermore, an often desired P2-hybrid variant is only implementable for small electric machines, even when replacing the torque converter.

With the help of the transmission synthesis program "PlanGear", developed by ZG GmbH, innovative transmission topologies, consisting of planetary gears, helical gears, dog clutches and more than two load shift elements, can be synthesized. Nevertheless, these topologies allow for an unrestricted load shiftability. By a reduced number of load shift elements in combination with compact dog clutches, planetary automatic transmissions (AT) can be realized as a P2-hybrid structure. Therewith, topologies synthesized in this way qualify excellently for transmissions with high power density in limited installation spaces.

This presentation will introduce an innovative hybrid transmission which reduces mechanical losses as well as installation space compared to conventional AT by using dog clutches and thereby ensuring full power shiftability (up and down shifts). The proposed gear box consists of only three planetary gear sets. With only three load shift elements and three dog clutches, six geometrically stepped gears can be implemented. By using another shift device, a mechanical reverse gear is integrated very compactly.

The structure of the transmission as well as the power flows and shiftability of the gears will be explained. Furthermore, the resulting dimension will be presented by a preliminary design draft of a P2 hybrid structure.

2 AT, DCT or MCT – comparison of transmission technologies

Increasing demand for comfort and efficiency leads to a higher market share of automatic transmissions. They offer a smoother driving experience without the need of changing gears manually and assist the driver in reducing the fuel consumption by choosing the suitable gear

for the current driving situation. Therefore, they can be found in an increasing amount of cars, even in compact vehicles of the B- and C-Segment.

In Europe and the western developed countries the most common transmission technologies besides manual gearboxes are Planetary Automatic Transmissions (AT) and Dual Clutch Transmissions (DCT). They both offer automated gear changes without torque interruption but use different principles and components.

AT consist of multiple planetary gear sets (PGS), which are coupled using disk clutches and brakes. A torque converter between motor and gearbox enables for smooth take-offs and a creep functionality for reversing and parking. Modern transmissions reduce the drag losses of the hydraulic torque converter by directly coupling motor and input shaft at higher speeds. The gear ratios for the different speeds are achieved by closing clutches and brakes. The shift elements couple different shafts of the planetary gear sets to each other or the housing and use the different ratios of the planetary gear sets. For changing the gear stage of the transmission, one friction element is opened while another one is closed. The torque is transferred almost seamlessly and the gear changes occur without traction force interruption.

DCT topologies are in principle similar to manual gearboxes and typically consist of helical gear stages with fixed ratios, which get coupled to the output shaft using synchronized dog clutches. They have two clutches connecting the motor shaft to two different shafts which represent the odd and even gears. This principle changes gears by switching torque from one clutch to the other. While the power flow of one gear is coupled to the motor, the next gear is preselected by engaging the respective synchronizers. According to the shift strategy, the next gear's power flow is activated by switching from the first to the second clutch.

On the one hand, AT typically have a high power density due to the use of planetary gear sets. High torques can be transmitted using multiple meshes between the central gears and the planets. On the other hand, DCT have a higher efficiency because of the synchronizers connecting the gears to the shafts and having less drag losses compared to the open friction shift elements of the AT. In addition, DCT have only one (or even no) open load shift element whereas AT typically have multiple open shift elements in every gear.

One attempt to combine the advantages of both concepts is to reduce the number of friction shift elements in AT. This can be achieved by substituting a friction disk clutch or brake with

a dog clutch [1]. However, this can influence the shift quality of the transmission because dog clutches can only be engaged while there is no or only a minimum speed difference between the connecting shafts.

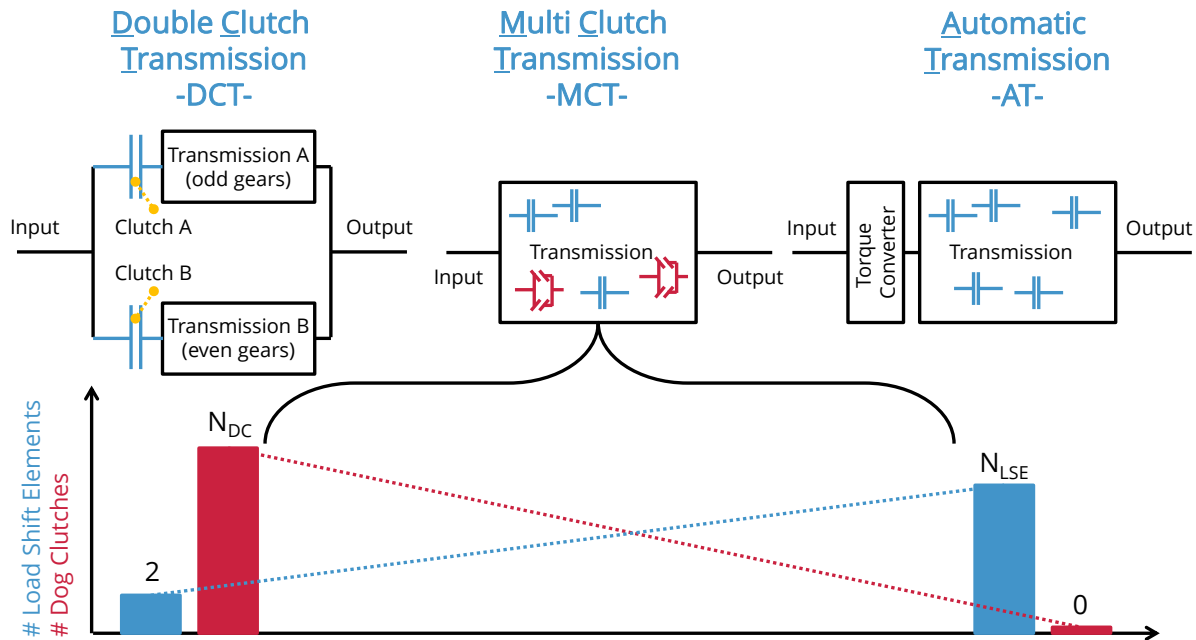

Fig 1: Characterization of MCT [2]

Multi-clutch transmissions (MCT) use the same approach and combine components of AT and DCT (see Fig. 1). DCT have two load shift elements (LSE) and typically one dog clutch per realized gear. AT are characterized by no dog clutches and a various number of LSE. In comparison to this two technologies, MCT have two or more LSE as well as different numbers of dog clutches. Nevertheless, they are (at least sequentially) power shiftable. Just as a DCT, MCT preselect the next gear using dog clutches and the power flow is engaged by closing one of the open LSE. MCT are not restricted to cylindrical gear stages, their structures can also be built by planetary gear sets or combinations of both. Thereby, the advantages of AT (e.g. high power density with planetary gears) are combined with those of DCT (e.g. few and robust LSE).

3 Transmission concept

The transmission synthesis program of ZG GmbH "PlanGear" can find various solutions for transmissions according to the search space. It is possible to search AT and DCT

transmission as well as combinations of both and to find hybridization solutions. It uses an analogy model to replace spur gears as well as planetary gears by levers (see [3] for further information). Therefore, PlanGear can be used in a very flexible way to synthesize all kinds of gear sets, such as complex compound planetary sets, cylindrical stages, differentials and more.

By adjusting the algorithm for AT-synthesis, the functionality of PlanGear was extended to also synthesize MCT solutions. The main difference between the algorithm for the AT-synthesis and the one for the MCT-synthesis is the criteria for shifting, because the preselection of the power flow for the next gear has to be considered. Consequently, it is substantial for the algorithm to differentiate between load-shift elements (LSE) and dog clutches. By specifying the maximum number of load shift elements and dog clutches (together with other boundary conditions), PlanGear will find all possible topologies that have less or equal numbers of LSE and dog clutches and fulfil all other requirements. Given that the number of permitted LSE is sufficient, PlanGear's MCT algorithm will also find AT solutions which use no dog clutches.

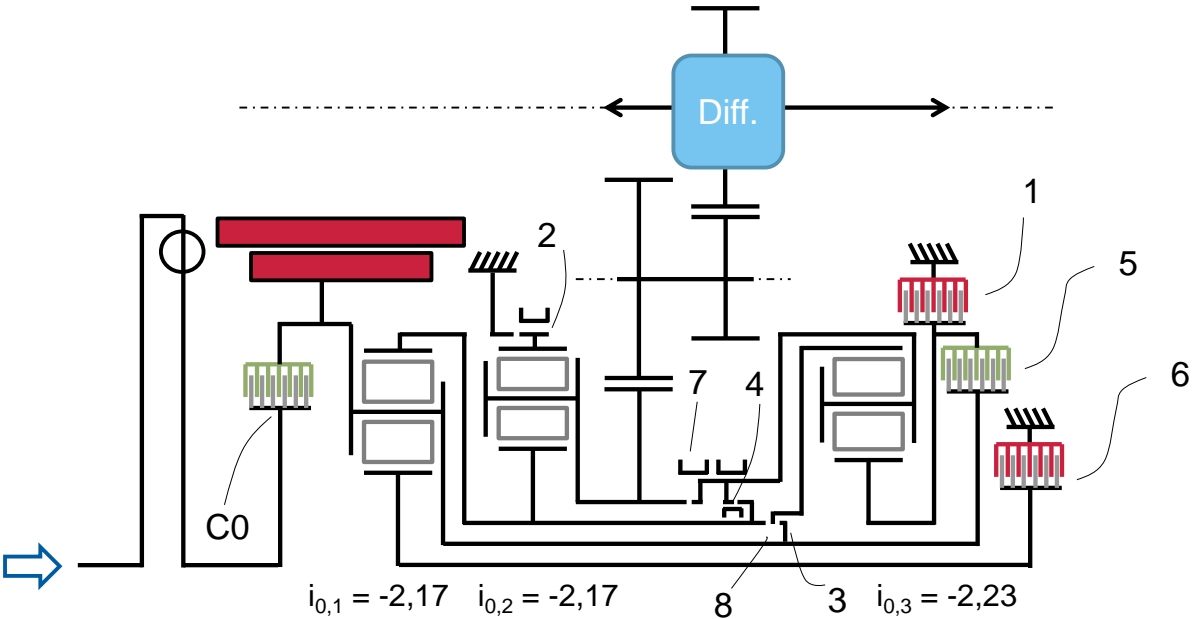

Fig 2: Topology of the 6-speed MCT

The defined search space for the here presented MCT allowed for up to three LSE and a total number of nine shift elements (meaning dog clutches and LSE combined) while demanding six speeds and one reverse speed. This structure was chosen among the other solutions because of its low shift element loads combined with the geometrical gear stepping

and a high ratio spread. For another case of application, the weighting of criteria would change and thereby other solutions would be preferred. Nevertheless the basic principles of MCT can be illustrated by this example.

Fig. 2 shows the topology of the 6-speed MCT. It consists of three planetary gear sets which are coaxially aligned on the input shaft and two helical gear stages, which connect the main transmission to the differential. The six forward speeds are realised by only three LSE whereas two of them are brakes (numbers 1 and 6) and one is a clutch (5). Additionally a C0 separator clutch can disconnect the internal combustion engine (ICE) from the transmission. The eight shafts of the transmission are coupled by three synchronized dog clutches for the forward speeds and two for the reverse speed.

The mechanical reverse gear is integrated to ensure full functionality of the transmission, even with very low state of charge of the battery. Normally, the e-motor should be used in the first gear for reversing the vehicle. If the mechanical reverse gear wasn't required, shift element 3 could be replaced by a solid connection between the shafts and shift element 8 could be left out.

Gear	Shift element Nr.								i	φ
	1	2	3	4	5	6	7	8		
1. Gear	L	x	x	x	L	L			14.796	
2. Gear		x	x	x	L	L			10.209	1.449
3. Gear		x	(x)	(x)	L	L			6.991	1.460
4. Gear	L	(x)	x		L	L	x		4.666	1.498
5. Gear			x		L	(0)	x		3.220	1.449
6. Gear			(x)	x	L	L	x		2.205	1.460
R Gear		x			L	L	x	x	-12.337	6.710

Fig 3: Shift matrix and gear ratios

The shift matrix in fig. 3 gives an overview of the shift elements and ratios of the gears. The columns for the LSE (1, 5 and 6) are coloured. Red represents a brake and green a clutch. The sign "L" symbolizes shifting under load (power shifting) for the LSE and "x" stands for an engaged dog clutch. The additional brackets indicate unloaded shift elements, meaning they can be opened without interrupting the power flow. The second to last column contains the ratio of every gear including the final drive stage and the last column shows the ratio step between two gears. This transmission has a geometrical stepping, meaning that all the ratio steps between the gears are nearly the same. This results in a high total spread of 6.710.

Shift element 1 is a load-shift brake connecting the sun shaft of the third PGS to the housing and is the starting element for a vehicle launch. This brake is engaged in first and fourth gear. Shift element 2 is another brake but is not power shiftable. The power flow of the first, second, third and reverse gear is determined by the engaged shift element which connects the ring gear of PGS 1 to the housing.

For every gear, one LSE and up to three dog clutches are closed, resulting in two open LSE, which produce drag losses (except for Gear 5, where LSE 6 is closed and operates as a dog clutch). To switch to the next gear, one of the LSE is opened and another one closed. Thus, the torque can be transmitted without interruption by overlapping the two clutches.

Gear	Shift element Nr.								i	φ
	1	2	3	4	5	6	7	8		
1. Gear	-0.460	-3.174	1.000	-1.460	1.000	1.685	0.469	-0.315	14.796	
1. Gear +	-0.460	-3.174	1.000	-1.460	1.000	1.685	0.469	-0.315		
2. Gear	1.000	-2.174	0.685	-1.000	0.315	1.000	0.685	0.000	10.209	1.449
2. Gear +	1.000	-2.174	0.685	-1.000	0.315	1.000	0.685	0.000		
3. Gear	2.460	-1.489	0.000	0.000	-1.460	0.315	1.000	0.460	6.991	1.460
3. Gear +	-0.714	-1.489	0.000	1.000	1.714	0.315	0.000	0.460		
4. Gear	-0.460	0.000	1.000	1.489	1.000	-1.552	1.460	1.174	4.666	1.498
4. Gear +	-0.460	0.328	1.000	0.775	1.000	0.000	1.460	0.460		
5. Gear	1.000	0.788	0.685	0.460	0.315	0.000	1.000	0.460	3.220	1.449
5. Gear +	1.000	1.000	0.685	0.000	0.315	1.000	1.000	0.000		
6. Gear	2.460	1.460	0.000	0.685	-1.460	0.315	0.685	0.460	2.205	1.460
R Gear	1.000	4.726	1.852	-0.583	1.000	5.026	3.174	2.174	-12.337	6.710

Fig 4: Shift element loads and speeds

Fig. 4 shows the loads every shift element has to transfer relative to the input torque. The LSE have to endure a maximum of 0.46 times the input torque for the forward speeds which is represented by the red (brake) and green (clutch) values in fig. 4. Blue values stand for non-engaged shift elements and display their relative rotational speed referred to the input speed. The low load of the LSE positively influences the dimensioning of the friction shift elements later on.

Table 1: Powerflows for the gears of the 6MCT

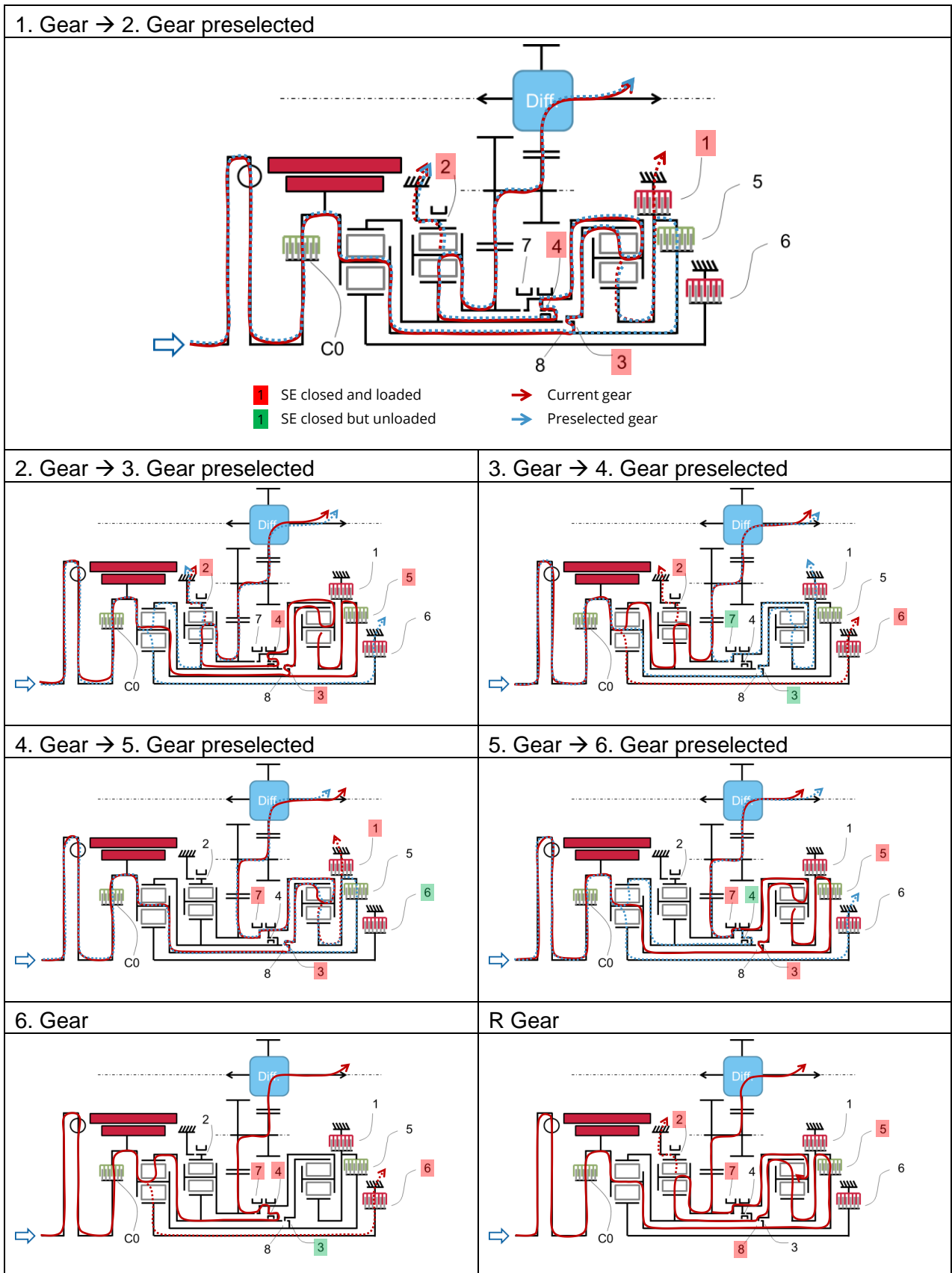

To illustrate the functionality of the MCT, the power flow for the first gear will be explained in detail (see table 1). According to fig. 3, four shift elements must be engaged for the first gear. To preselect the power flow, brake 2 as well as clutch 3 and 4 have to be closed. To transfer power to the output, respectively to launch the vehicle, LSE 1 is engaged like a regular friction brake of a transmission. Similar to a DCT, the next gear has to be preselected before the transmission can shift the gears. In the case of this transmission, the required dog clutch elements for gear 1 and 2 are the same. Consequently, gears can be changed by simply opening LSE 1 and simultaneously engaging LSE 5. Furthermore, there is another power shift available when you want to change from gear 1 to a higher gear. By closing LSE 6, the power flow for speed 3 is enabled. Shift elements 3 and 4 can still be closed, but no longer transmit power. As shown in table 1, the loaded dog clutches for gears 1 to 3 are the same, only the LSE are changed from gear to gear. To preselect gear 4, the unloaded dog clutch 4 is opened and dog clutch 7 gets engaged, but does not transmit power. For the gear change, the transmission switches from LSE 6 to LSE 1 and the power flow for gear 4 is activated. Due to the preselection of gears, the transmission cannot power shift from one gear to every other. The power flow of the preselected gear must not intersect with the one of the actual gear. Still the sequential power shiftability (from one gear to the next one) is not restricted. In addition, further power shifts are possible (see fig 5), such as the shift from 1 to 3, from 3 to 5 and from 4 to 6.

	To	1.	2.	3.	4.	5.	6.	R
From		Gear	Gear	Gear	Gear	Gear	Gear	Gear
1. Gear		-	X	X				
2. Gear		X	-	X				
3. Gear		X	X	-	X	X		
4. Gear				X	-	X	X	
5. Gear				X	X	-	X	
6. Gear					X	X	-	
R Gear								-

Fig 5: Power shiftability of the gears

4 Prototype design features

To prove the potential of the concept, a preliminary design was created including a housing design and the dimensioning of the gear stages and shift elements. Fig. 6 shows a first draft of the transmission design and the integrated components. The electric motor is situated between the ICE and the transmission. It is integrated in the transmission housing instead of a conventional torque converter. Around the stator of the e-machine, a cooling jacket, which is supplied with cooling fluid by external connections, is installed to maximize energy output of the e-motor. With an active length of approximately 55 mm it is designed to deliver around 150 Nm of maximum torque. In the presented design, the diameter of the e-motor roughly aligns with the dimensions of the brake 2 at the ring gear of the secondary PGS. Due to the required diameter for the flywheel, the flange to the ICE is bigger than the outer diameter of the e-motor. Consequently, the diameter and therewith the maximum torque of the e-motor can be adjusted easily to higher values.

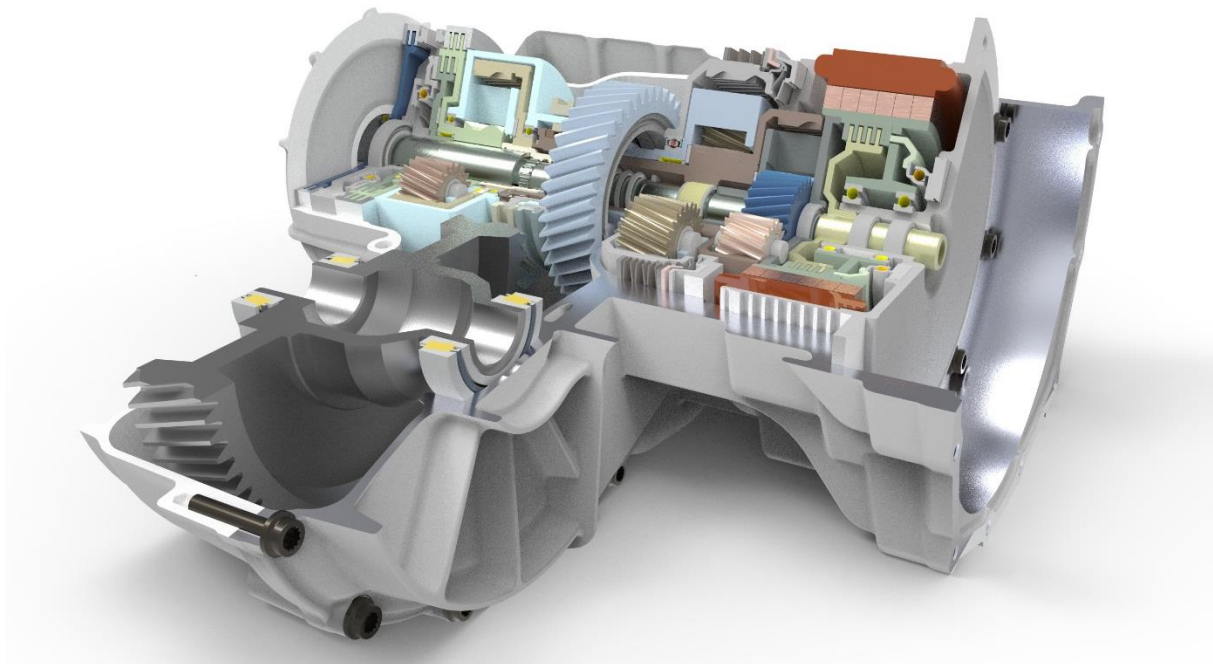

Fig 6: Crosssection of the 6MCT (preliminary design)

Underneath the rotor, the separator clutch C0 can disconnect the e-motor from the internal combustion engine to minimize losses during electric driving. Furthermore, the rotor can be cooled by injectors being supplied with oil from the housing.

The hydraulic unit for the transmission is situated at the front side of the housing, next to the load shift elements. In this way, the pistons of the LSE can easily be supplied with pressure oil through the housing. Additionally, the actuators of the shift forks for the synchronized dog clutches can be integrated directly in the hydraulic unit.

The preliminary design with gears, bearings and shift elements sums up to an axial length of about 304 mm without the e-motor and together with the e-motor of about 374 mm, whereas the centre distance between input and output shaft is 190 mm.

4.1 Gear Set

The gear set is designed to take a combined input torque of about 500 Nm. The planetary gear sets have almost the same stationary ratio (see fig. 2) but are loaded differently which leads to higher diameters for the second and third PGS compared to the first PGS. To reduce axial length, the planetary gear sets are equipped with up to five planets. Consequently, the load of the central gears is split to more gear meshes and results in a high power density. Because of the relatively low stationary ratio of about $i_0 = -2.2$, the planets can be fitted easily inside the carrier. A higher stationary ratio would lead to bigger planets and thus limit the amount of planets which can be fitted inside the carrier without significantly reducing the stiffness of the carrier.

The final drive consists of two helical gear stages with ratios -1.28 and -2.52. In combination they provide a ratio of 3.23 between the main transmission and the differential. The pinion of the first stage connects to the planet carrier of the second PGS. Because of the high torque in the mesh between pinion and wheel of the helical gear stage, large radial and axial forces are transmitted to the shaft and would affect the mesh between teeth of the PGS by deflecting the carrier. To reduce this effect, the pinion directly mounts to the housing using two roller bearings.

Table 2: Efficiency of the transmission according to ISO 14179-1

Gear	1	2	3	4	5	6
Efficiency	97,63 %	98,43 %	98,08 %	98,61 %	99,25 %	98,76 %

According to ISO 14179-1, the losses of the gears and bearings were calculated for an input speed of 3000 rpm and a combined input torque of 500 Nm to evaluate the efficiency of the transmission (see table 2). The calculation includes the planetary gear sets as well as the helical gear sets of the final drive and all bearings, whereas gear windage and churning

power loss is not regarded. Gears 2 to 6 have a high efficiency of over 98 %. Only the first gear has a lower efficiency of 97.63 %, which is acceptable because of its low time share in typical load cycles.

The lay shaft for the wheel of the first stage and the pinion of the second stage also mounts the parking lock wheel. Due to this, the torque of the engaged park lock gets multiplied by the ratio of the second helical stage.

4.2 Shift elements

The shift elements significantly influence the required installation space of the transmission. Thus, their arrangement needs to be considered carefully. The load shift elements are grouped together at the end of the transmission and are nested into each other to reduce the axial length. Brakes 1 and 6 use the maximum diameter of the housing to maximize the effective diameter and the friction surface. Both are actuated by hydraulic pistons. They fit in a bearing shield which also supports the carrier shaft of the first planetary gear set and another hydraulic piston for clutch 5. This load shift element between the sun shaft of the third PGS and the carrier shaft of the first PGS is engaged by a piston and an axial push bearing. In this way, the oil for the hydraulic piston can flow from the housing trough the bearing shield to the piston. Thereby, no rotary joint to supply the piston with pressure oil from a shaft is needed. The diameters of the friction shift elements and the number of plates in this design are determined by the transferred torque and the bearable surface pressure.



Fig 7: Brake 2 (preliminary design)

Brake 2 connects the ring gear of the second planetary transmission to the housing and is engaged during first, second and third gear. The large diameter makes it unsuitable for a conventional synchronized dog clutch. Instead, an innovative design from Hoerbiger is applied. The TorqueLINE Cone Clutch [4] basically combines the advantages of a dog clutch and a friction disk clutch. A piston, similar to a friction clutch, engages the TorqueLine Clutch by initially pushing against a friction element. The friction element (see fig. 7) is conical and has two friction plates comparable to a synchronizer unit. After minimizing the relative speed of the friction partners and establishing a frictional connection between the housing and the shaft, the piston moves further and connects the shift plate to the ring gear with form fit.

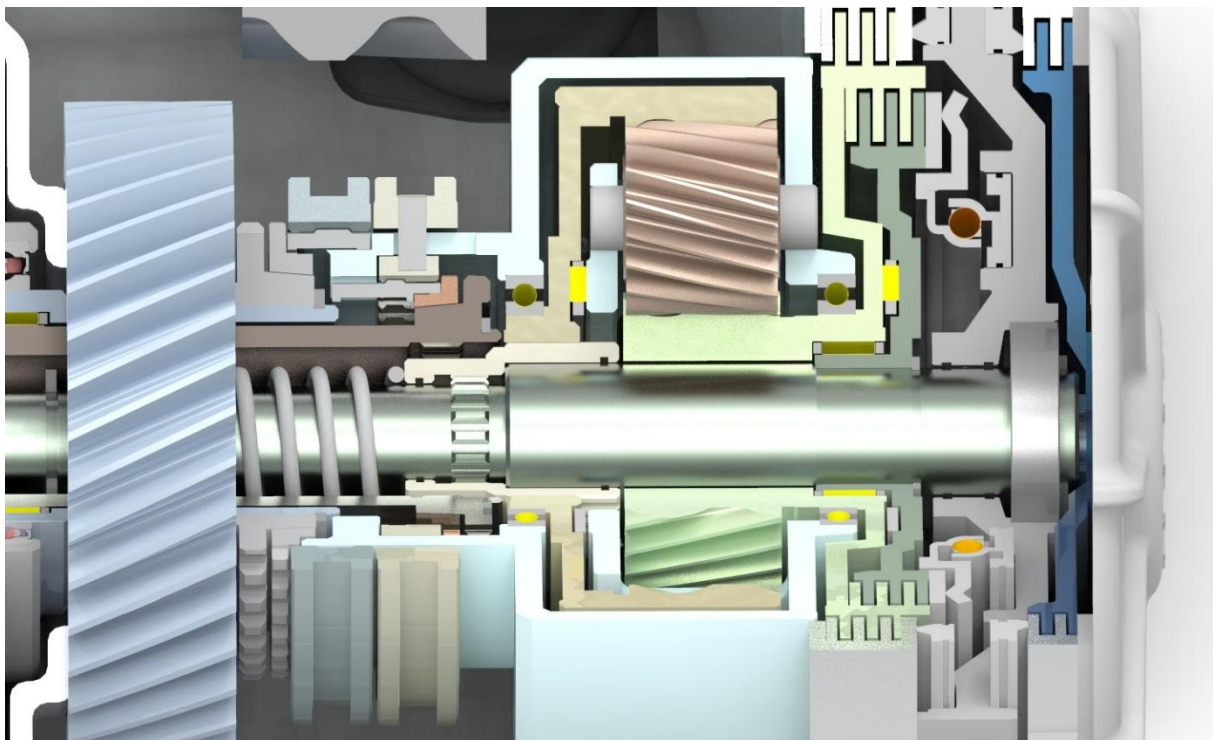

Fig 8: Shift elements 4 and 7 (preliminary design)

Shift elements 4 and 7 are conventional synchronized dog clutches and are actuated by shift forks (see fig. 8). The shift forks mount to the housing and can be driven directly from the hydraulic unit of the gear box. Both shift elements require their own shift fork because in gear 6 they are simultaneously actuated. On the one hand, it is disadvantageous for the concept because it requires more parts. On the other hand, the single synchronizers themselves are less complex than a combined synchronizer element.

Shift elements 3 and 8 can be combined to one group because they engage alternately. They connect the ring gear of the third PGS to either the carrier or to the ring gear of the first PGS. Because of their position, they are difficult to reach with a shift fork and would increase complexity and installation space of the transmission. Beneficially, shift element 3 is engaged during all forward speeds and only needs to be opened for the mechanical reverse gear, which is only needed when the vehicle cannot be reversed electrically. The shift from forward to reverse speed typically takes place during standstill or at very low speeds. Therefore, shift elements 3 and 8 need no synchronization or the shift process can be assisted by the electric motor. This leads to a very simplified and compact design of the shift element. A piston (light yellow colour, see fig 9) can slide on the shaft of the first planetary carrier. A splined shaft connection between both parts allows the axial movement but transmits torque between the inner and outer part. A bore supplies the piston with oil pressure and is fed from the bearing shield at the end of the shaft. The applied oil pressure moves the piston towards the input of the transmission and the splined shaft connects to the shaft of the sun gear (orange) of the second PGS. This equals the engaged shift element 8 for the reverse gear. As soon as the oil pressure is reduced, the integrated spring pushes the piston back to its initial position and thus engaging shift element 3 for gears 1 to 6.

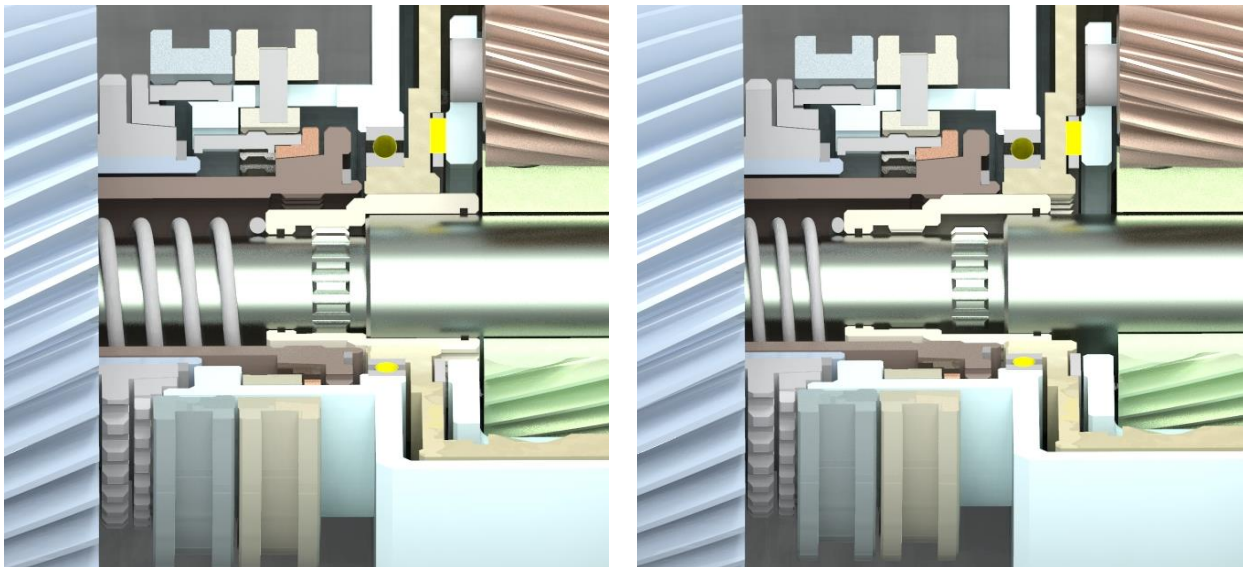

Fig 9: Detail of SE 3 and 8 – left: SE 3 engaged; right: SE 8 engaged (preliminary design)

5 Summary and Outlook

MCT combine the advantages of AT and DCT in efficient and compact transmission topologies. This feasibility study of a six-speed MCT for front-transverse application proves the potential of multi-clutch transmissions to provide a highly functional transmission with high power density, a high ratio spread and high efficiency. This is achieved by reducing drag losses of open shift elements by the use of dog clutches in a power shiftable transmission design.

In a first design draft, the three load shift elements, five dog clutches and three planetary gear sets were arranged in a way, to form a compact transmission with an axial length of 374 mm and a centre distance of 190 mm to suit typical requirements for front-transverse applications. The e-motor is integrated in the housing instead of a conventional torque converter and offers the possibility for a hybrid transmission in P2-design. Furthermore, a C0 separator clutch is fitted between internal combustion engine and e-motor, to allow for reduced losses during electrical operation of the vehicle.

The introduced transmission design is one representative of multi-clutch transmissions. Projects for customers showed further possibilities for the implementation of MCT, for example transmissions with larger number of speeds (e. g. 8 or 9) or solutions for very cost-sensitive applications, where the reduced complexity but high functionality performed better than conventional AT or DCT solutions.

References

- [1] M. Ebenhoch, J. Greiner, L. Gärtner and G. Girres, 9-speed transmission for front wheel drive applications. VDI-Kongress: Getriebe in Fahrzeugen, Friedrichshafen, 2013
- [2] C. Wirth and A. Garcia, AT or DCT? MCT – The best of both worlds! VDI-Kongress: Getriebe in Fahrzeugen, Bonn, 2017
- [3] C. Wirth, M. Ernstorfer and A. Fuchs, Das Getriebesyntheseprogramm der ZG GmbH. VDI-Kongress: Getriebe in Fahrzeugen, Friedrichshafen, 2014
- [4] P. Echtler, M. Mileti and A. Damm, TorqueLINE Cone Clutch – Konische Kupplung mit Formschluss als alternatives Schaltelement für Automatikgetriebe. VDI-Fachtagung: Kupplungen und Kupplungssysteme in Antrieben, Karlsruhe, 2017